

**Sena**  
LG16-SEN

*Adjustable Shower Column*  
*Columna de Ducha Ajustable*  
*Colonne De Douche Réglable*

## Quick Installation Guide Guía de Instalación Rápida Guide d'Installation Rapide

Installation Support • Soporte de Instalación • Support d'Installation

**Personal Assistance, Product Specs, & "How-to" Questions:**

Asistencia personal, especificaciones del producto y preguntas sobre "cómo hacerlo":

Aide personnelle, spécifications du produit et questions « pratico-pratiques » :



**WARNING / ADVERTENCIA / AVERTISSEMENT**

To reduce the risk of injury or property damage, read all instructions before installing product. Wear safety goggles. Product must be installed in accordance with all state & local plumbing & building codes. This product may take two people to install. Call a professional if you are uncertain about installing this product.

Para disminuir el riesgo de lesiones o daños a la propiedad, lea todas las instrucciones antes de instalar el producto. Utilice gafas de seguridad. El producto deberá instalarse de acuerdo con la normativa de plomería y construcción estatal y local. Este producto se puede tomar a dos personas para instalar. Llame a un profesional si no está seguro sobre cómo instalar este producto.

Pour réduire le risque de blessures ou de dommages, lire toutes les instructions avant d'installer le produit. Porter des lunettes de sécurité. Le produit doit être installé en conformité avec tous les codes de construction et de plomberie locaux et de l'état. Ce produit peut prendre deux personnes pour installer. Appelez un professionnel si vous n'êtes pas certain de la façon d'installer ce produit.

**Required Tools**

**Herramientas necesarias**  
**Outils nécessaires**

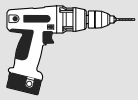

Power Drill  
Taladro Eléctrico  
Foreuse Électrique



Hammer  
Martillo  
Marteau



PTFE plumber's tape  
Cinta para plomería PTFE  
Ruban PTFE de plombier



1/2" or 1/8" Bit  
1/2" o 1/8" Broca  
1/2" ou 1/8" Foret



Level  
Burbuja de nivel  
Niveau à Bulle



Pencil  
Lápiz  
Crayon



Caulking  
Calafateo  
Calfeutrage



Safety Goggles  
Gafas de seguridad  
Lunettes de sûreté

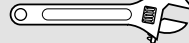

Adjustable Wrench  
Llave ajustable  
Clé à Mollette



Phillips Screwdriver  
Destornillador de estrella  
Tournevis Phillips

**Additional Helpful Tools**  
**Otras herramientas útiles**  
**Outils supplémentaires utiles**

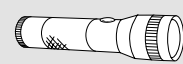

Flashlight  
Linterna  
Lampe-torche



Cloth  
Paño de limpieza  
Chiffon

**Parts in the Box • Piezas en la caja • Pièces dans la boîte**



A



B



C



D



E



F



G (x2)



H (x2)

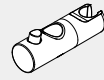

J



K

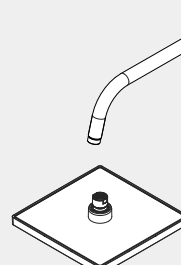

L



M



N

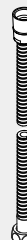

P



Q



R

**1**

**Turn Off Water Supply • Cierre el suministro de agua • Couper l'alimentation en eau**



Locate water supply inlets and shut off the water supply valves. These are usually found near the water meter. If you are replacing an existing unit, remove the old unit and clean the mounting surface thoroughly.

Localice las entradas de suministro de agua y cierre las válvulas de suministro de agua. Estos se encuentran generalmente cerca del medidor de agua. Si está reemplazando una unidad existente, retire la unidad antigua y limpie a fondo la superficie de montaje.

Localisez les entrées d'alimentation en eau et fermez les vannes d'alimentation en eau. Ceux-ci se trouvent généralement près du compteur d'eau. Si vous remplacez une unité existante, retirez l'ancienne unité et nettoyez soigneusement la surface de montage.

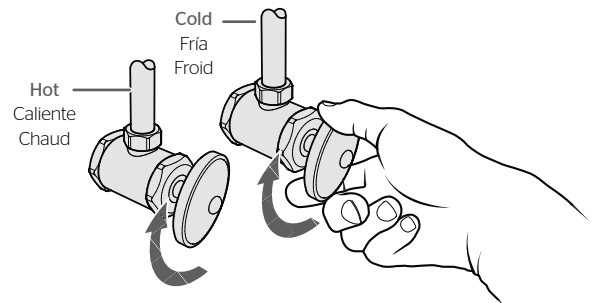

# 2

## Assemble the Column Ensamblar la Columna Assembler la Colonne



Power Drill  
Taladro Eléctrico  
Foreuse Électrique



Pencil  
Lápiz  
Crayon



Hammer  
Martillo  
Marteau

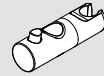

J



K

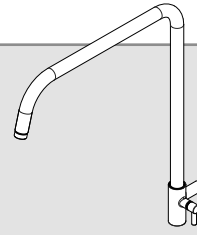

M



N

### 2A

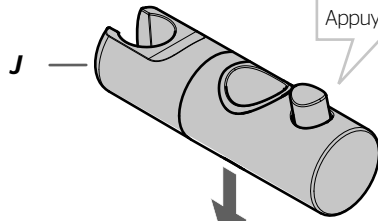

Press button to slide on.  
Presione el botón para deslizarlo.  
Appuyez sur le bouton pour glisser.

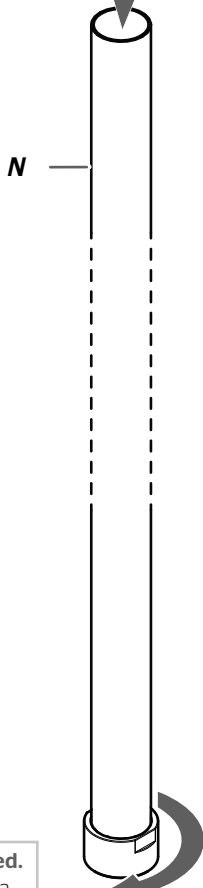

N

Ensure washer is installed.  
Asegúrese de que la lavadora  
esté instalada  
Assurez-vous que la rondelle  
est installée

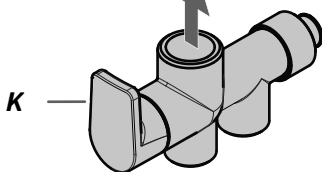

K

### 2B

Turn to unlock  
Girar para desbloquear  
Tournez pour déverrouiller

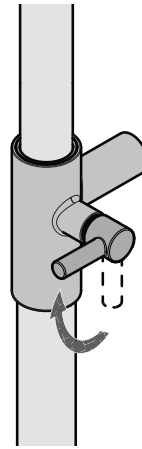

### 2C

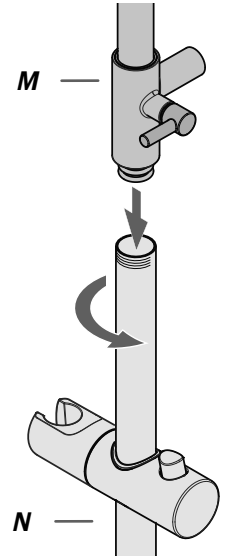

### 2C

Turn to lock  
Girar para bloquear  
Tourner pour verrouiller

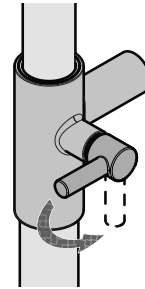

Height of Shower Head is Adjustable  
La altura del cabezal de la ducha es ajustable  
La hauteur du pommeau de douche est réglable

Adjustable

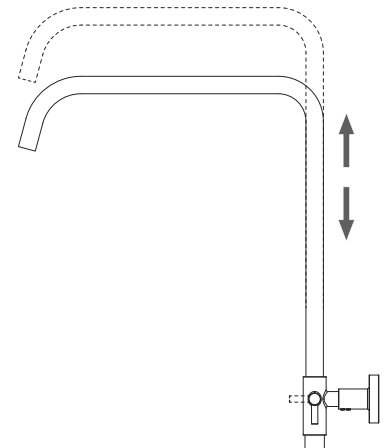
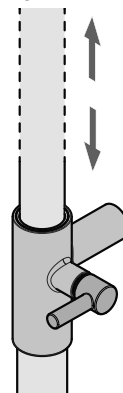

### 3 Prepare Top of Column and Wall Support

#### Preparar la parte superior de la columna y su soporte de pared

#### Préparer le haut de la colonne et son support mural



Power Drill  
Taladro Eléctrico  
Foreuse Électrique



Pencil  
Lápiz  
Crayon

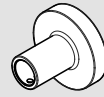

B



C



D

#### Note • Nota • Note

Place column against wall to note where you want to install.

Coloque la columna contra la pared para indicar dónde desea instalarla.

Placez la colonne contre le mur pour noter l'endroit où vous souhaitez l'installer.

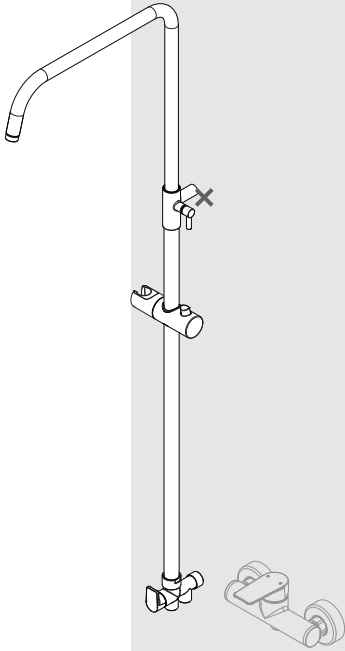

#### 3A

##### Check the install dimension before drilling

Verifique dimensión de instalación antes de perforar

Vérifiez dimensions d'installation avant de percer

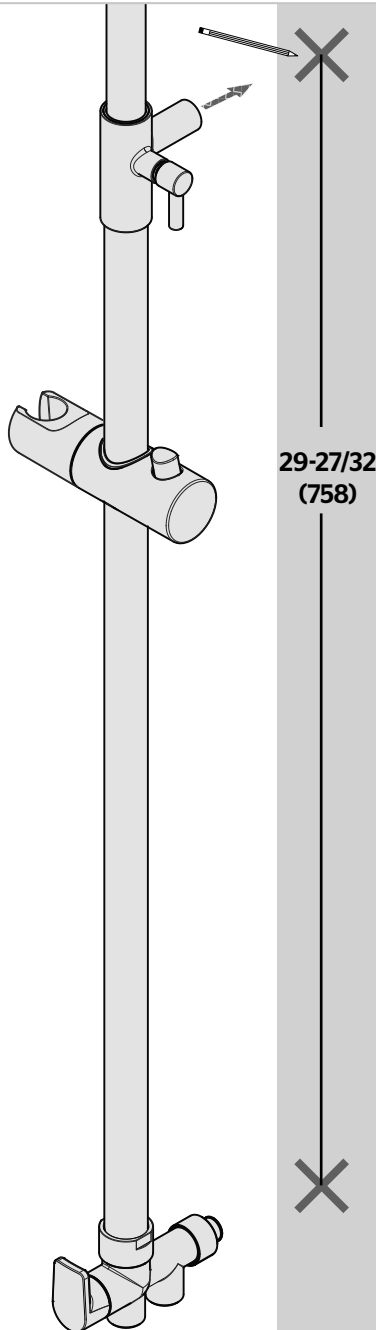

#### 3B

##### Drill a 1/4" hole.

Taladre un agujero de 1/4".  
Percer un trou de 1/4 po.

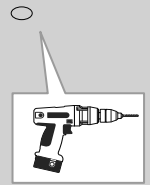

#### 3C

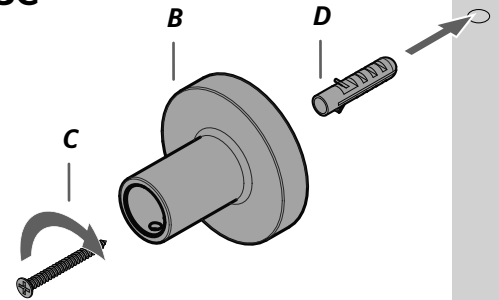

# 4 Prepare Bottom of Column Wall Support

## Preparar la parte inferior de la columna de soporte de pared

### Préparer le bas du support mural de la colonne

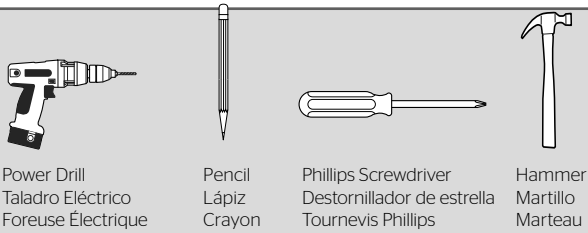

#### Note • Nota • Note

Place column against wall to note where you want to install.  
Coloque la columna contra la pared para indicar dónde desea instalarla.  
Placez la colonne contre le mur pour noter l'endroit où vous souhaitez l'installer.

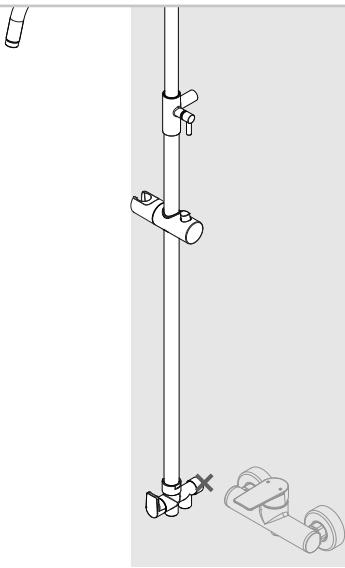

#### 4A

##### Use to mark desired locations.

Utilice para marcar localizaciones deseada.  
Employez pour marquer des endroits désiré.

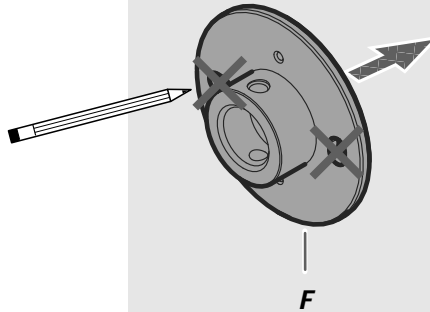

#### 4B

##### WALL Installation Instalación del PARED Installation dans les MUR

**Drill two 1/4" holes.**  
Taladre dos agujeros de 1/4".  
Perçer deux trous de 1/4 po.

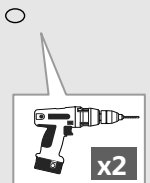

#### 4C

##### WALL Installation Instalación del PARED Installation dans les MUR

**Drill two 1/4" holes.**  
Taladre dos agujeros de 1/4".  
Perçer deux trous de 1/4 po.

##### Remove film before placing on wall.

Retire la película antes de colocarla en la pared.  
Retirer le film avant de le placer sur le mur.

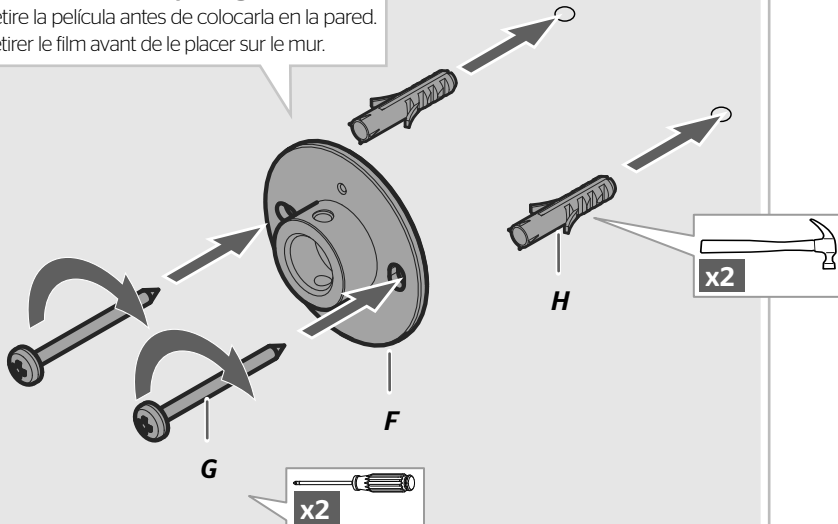

# 5

## Install Shower Column

### Instale la columna de ducha

### Installer la colonne de douche



Level  
Burbuja de nivel  
Niveau à Bulle

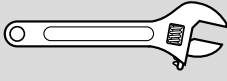

Adjustable Wrench  
Llave ajustable  
Clé à Mollette



Caulking  
Calafateo  
Calfeutrage



E



R

### 5A

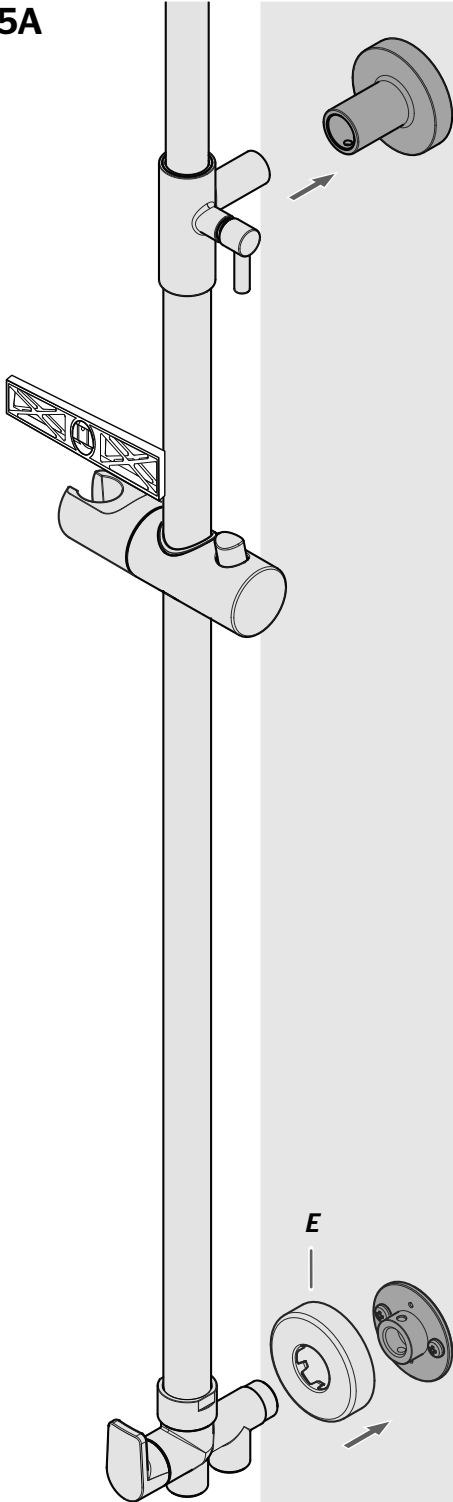

### 5B

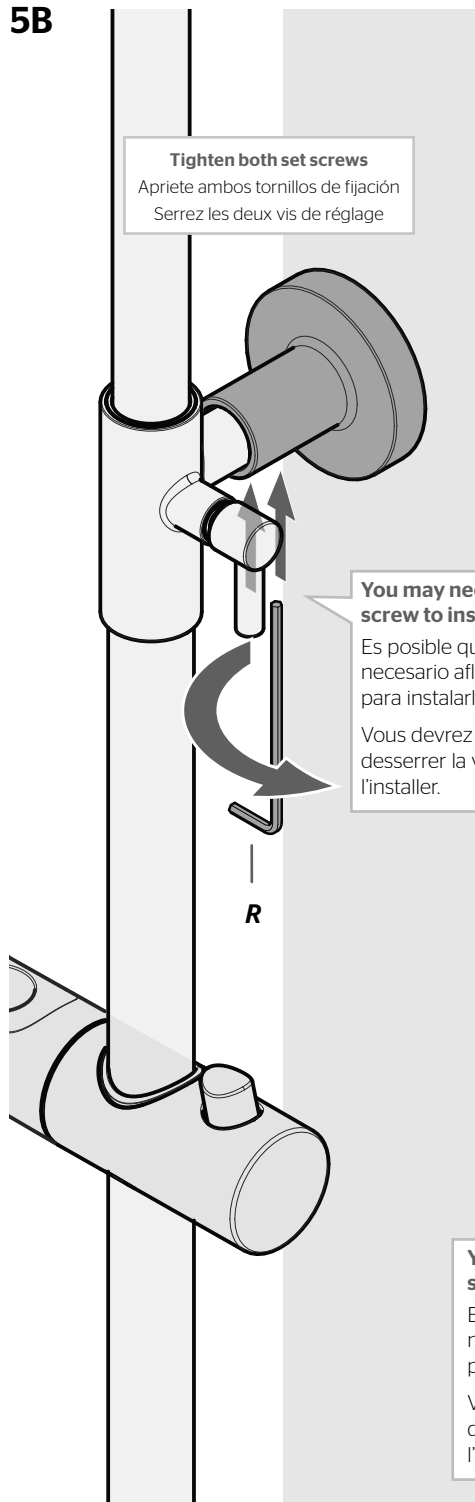

**Tighten both set screws**  
Apriete ambos tornillos de fijación  
Serrez les deux vis de réglage

**You may need to loosen screw to install.**  
Es posible que sea necesario aflojar el tornillo para instalarlo.  
Vous devrez peut-être desserrer la vis pour l'installer.

### 5C

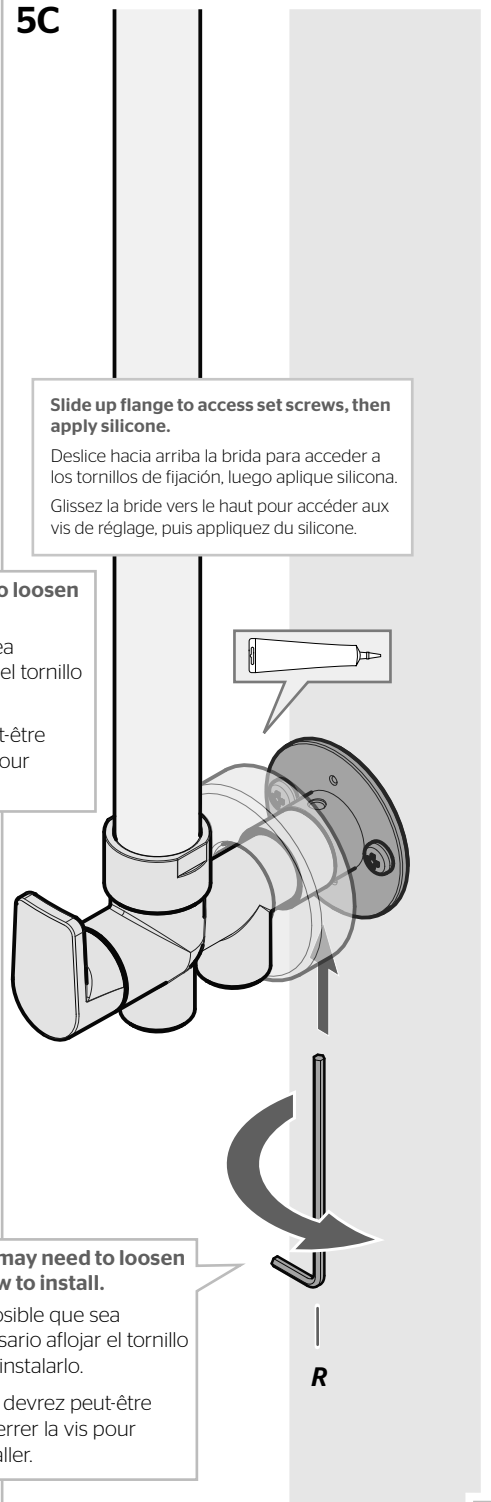

**Slide up flange to access set screws, then apply silicone.**  
Deslice hacia arriba la brida para acceder a los tornillos de fijación, luego aplique silicona.  
Glissez la bride vers le haut pour accéder aux vis de réglage, puis appliquez du silicone.

**You may need to loosen screw to install.**  
Es posible que sea necesario aflojar el tornillo para instalarlo.  
Vous devrez peut-être desserrer la vis pour l'installer.

# 6 Install Shower Head and Handheld

## Instale la cabeza de ducha y la ducha de mano

### Installer le pommeau de douche et une douche à main

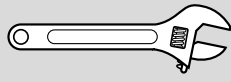

Adjustable Wrench  
Llave ajustable  
Clé à Mollette



A

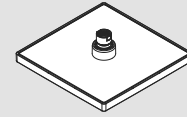

L



P

6A

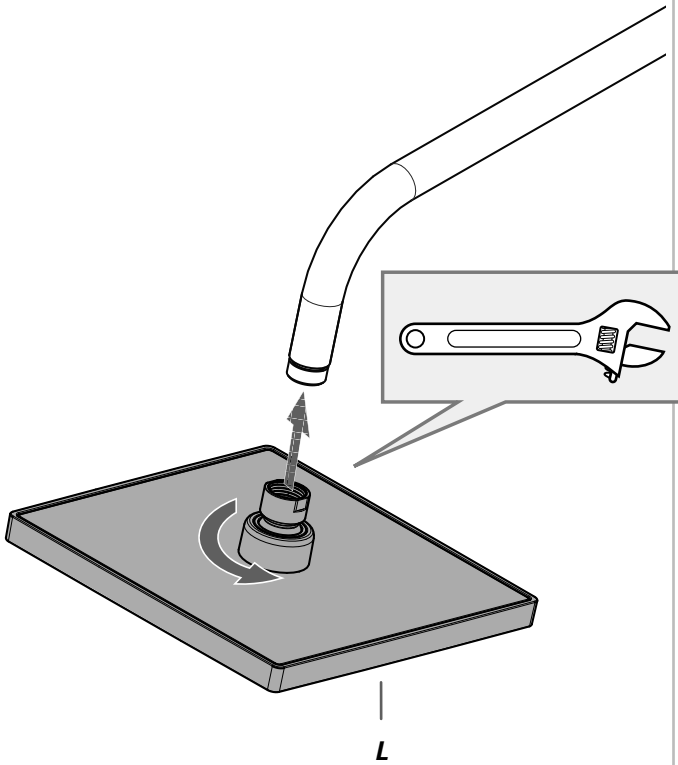

6B

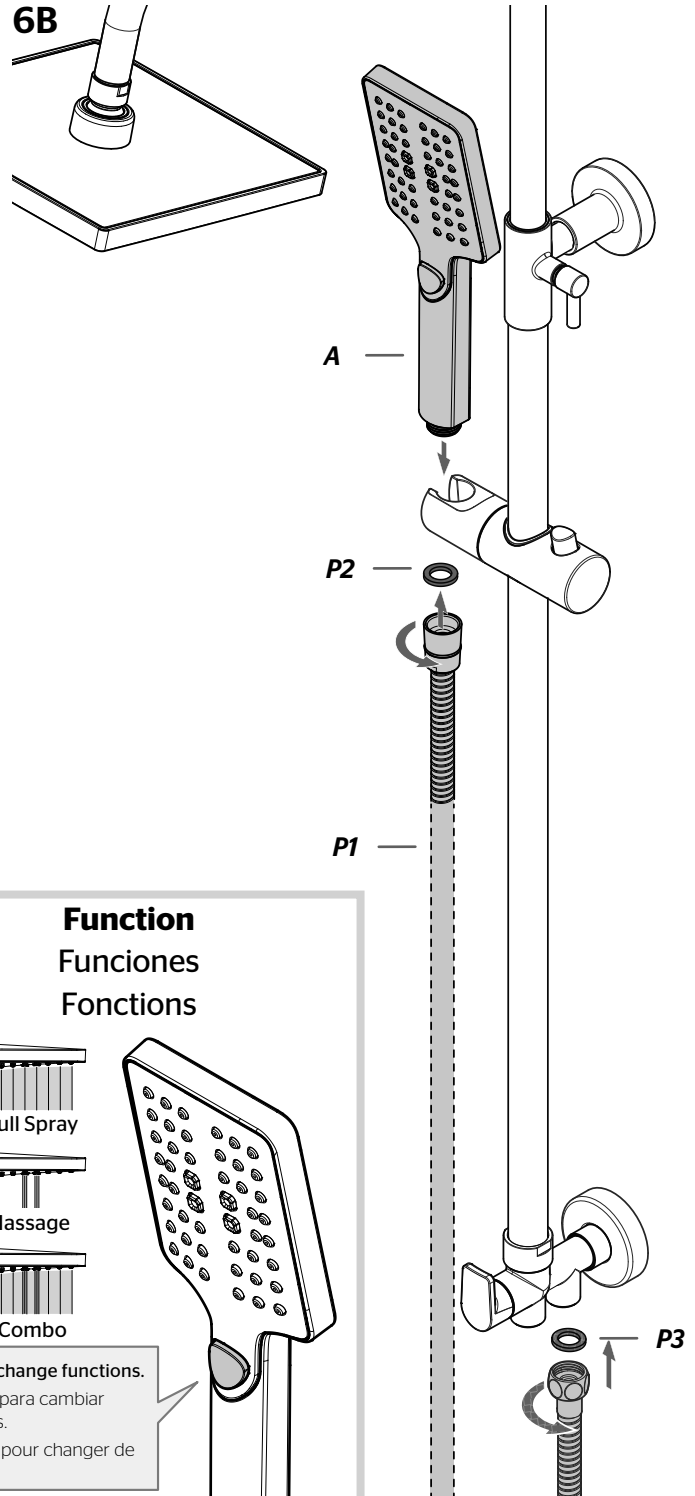

**Tip • Indicio • Conseil**

Wrap with a towel to protect finish from wrench  
Envolper con una toalla para proteger el acabado de la llave.  
Envelopper avec une serviette pour protéger le fini de la clé.

**Function  
Funciones  
Fonctions**

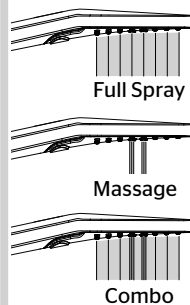

Full Spray

Massage

Combo

Press to change functions.  
Presione para cambiar funciones.  
Appuyez pour changer de fonction.

# 7

## Install Water Connection

Instalar conexión de agua

Installer un raccordement d'eau

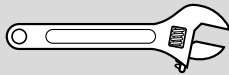

Adjustable Wrench  
Llave ajustable  
Clé à Mollette



Q

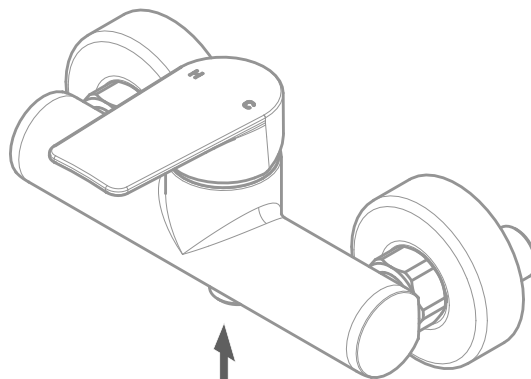
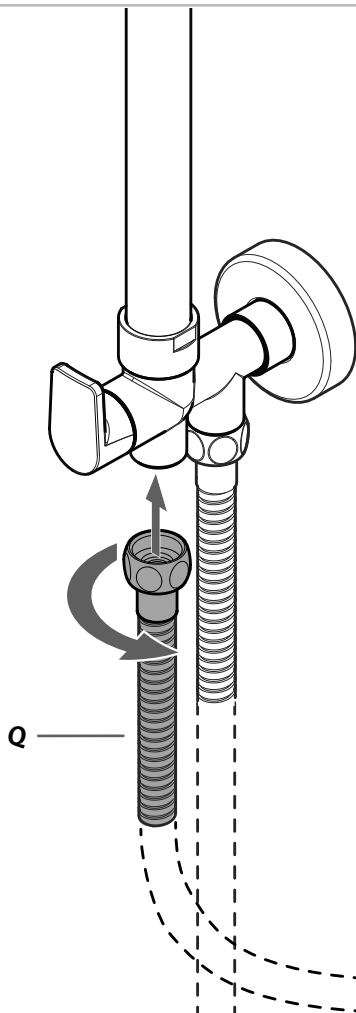

Install to Shower Valve Per Manufacturer's Instructions

Instalar en la válvula de ducha según las instrucciones del fabricante

Installer sur la vanne de douche selon les instructions du fabricant

Suggestion: Install with 8E5-SEN or 8E8-SEN

Sugerencia: Instalar con 8E5-SEN o 8E8-SEN

Suggestion : installer avec 8E5-SEN ou 8E8-SEN

## 8 Turn On Water & Confirm Proper Installation

Active el suministro de agua y confirme que la instalación está adecuadamente efectuada

Ouvrez l'eau et confirmez que l'installation est adéquate

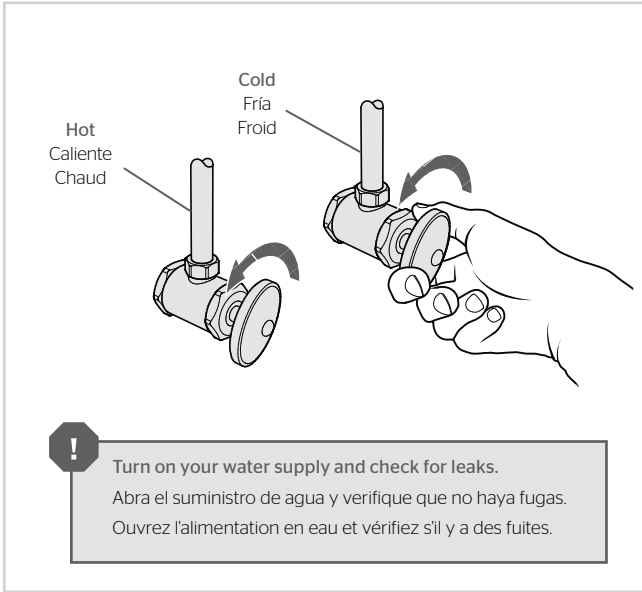

## 9 Cradle Adjustments

Ajustes de Cuna

Ajustements du berceau

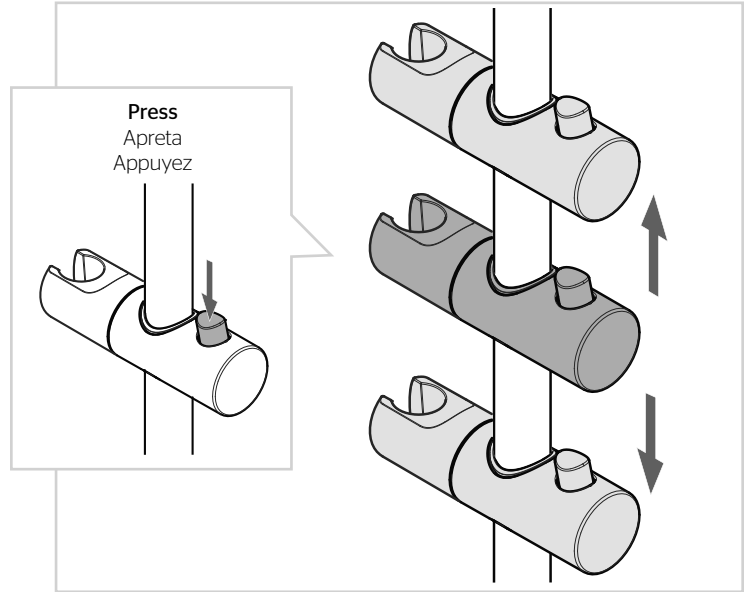

## 10 How to Use Diverter

Cómo utilizar el Desviador

Comment utiliser le Déviateur

