

Installation Support • Soporte de Instalación • Support d'Installation

Personal Assistance, Product Specs, & "How-to" Questions:

Asistencia personal, especificaciones del producto y preguntas sobre "cómo hacerlo":

Aide personnelle, spécifications du produit et questions « pratique-pratiques » :



WARNING / ADVERTENCIA / AVERTISSEMENT

To reduce the risk of injury or property damage, read all instructions before installing product. Wear safety goggles. Product must be installed in accordance with all state & local plumbing & building codes. Call a professional if you are uncertain about installing this product.

Para disminuir el riesgo de lesiones o daños a la propiedad, lea todas las instrucciones antes de instalar el producto. Utilice gafas de seguridad. El producto deberá instalarse de acuerdo con la normativa de plomería y construcción estatal y local. Llame a un profesional si no está seguro sobre cómo instalar este producto.

Pour réduire le risque de blessures ou de dommages, lire toutes les instructions avant d'installer le produit. Porter des lunettes de sécurité. Le produit doit être installé en conformité avec tous les codes de construction et de plomberie locaux et de l'état. Appelez un professionnel si vous n'êtes pas certain de la façon d'installer ce produit.

Required Tools

Herramientas necesarias
Outils nécessaires

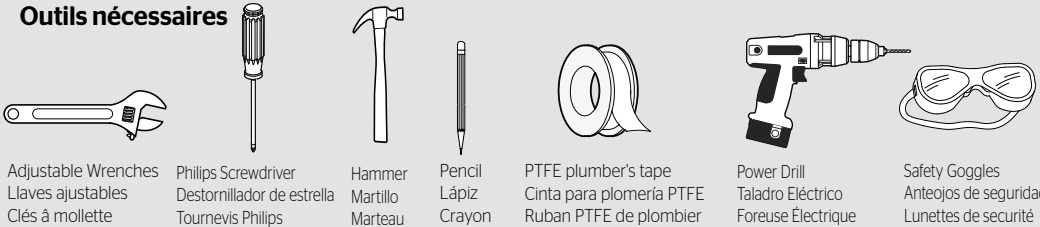

Adjustable Wrenches
Llaves ajustables
Clés à mollette

Philips Screwdriver
Destornillador de estrella
Tournevis Philips

Hammer
Martillo
Marteau

Pencil
Lápiz
Crayon

PTFE plumber's tape
Cinta para plomería PTFE
Ruban PTFE de plombier

Power Drill
Taladro Eléctrico
Foreuse Électrique

Safety Goggles
Anteojos de seguridad
Lunettes de sécurité

Additional Helpful Tools
Otras herramientas útiles
Outils supplémentaires utiles

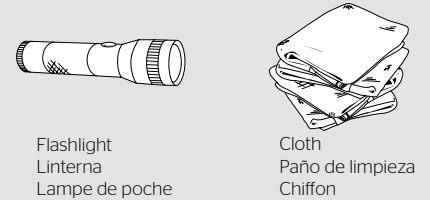

Flashlight
Linterna
Lampe de poche

Cloth
Paño de limpieza
Chiffon

Parts in the Box

Piezas en la caja
Pièces dans la boîte

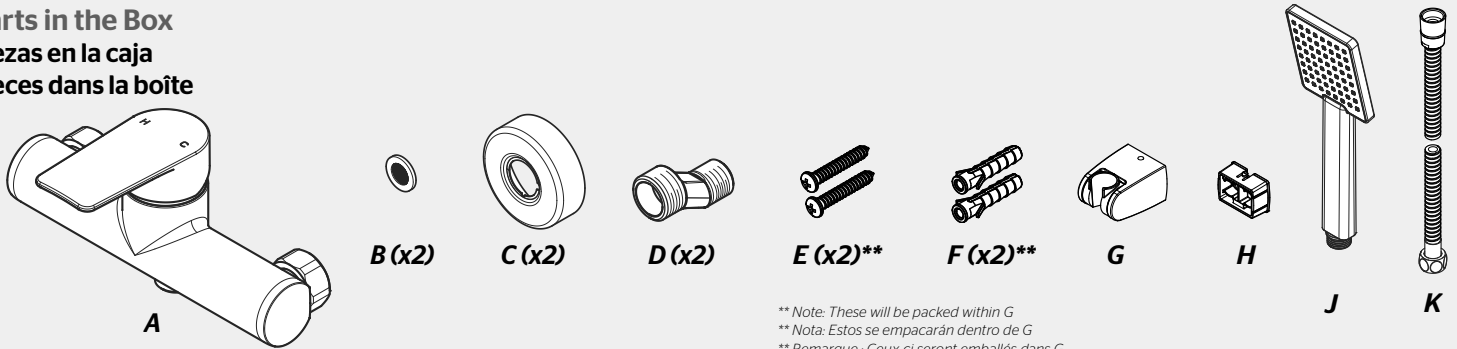

** Note: These will be packed within G
** Nota: Estos se empaquetarán dentro de G
** Remarque: Ceux-ci seront emballés dans G

1 Turn Off Water Supply • Cierre el suministro de agua • Couper l'alimentation en eau



Locate water supply inlets and shut off the water supply valves. These are usually found under the sink or near the water meter. If you are replacing an existing faucet, remove the old faucet from the sink and clean the sink surface thoroughly.

Ubique las entradas del suministro de agua y cierre las válvulas de suministro de agua. Generalmente se encuentran debajo del fregadero o cerca del medidor de agua. Si se trata de un reemplazo de grifo, quite el grifo viejo y limpie completamente la superficie del fregadero.

Recherchez les entrées d'approvisionnement et fermer les robinets. Ces robinets se trouvent généralement sous l'évier ou près du compteur d'eau. En cas de remplacement d'un robinet existant, retirez le de l'évier et nettoyer soigneusement la surface de ce dernier.

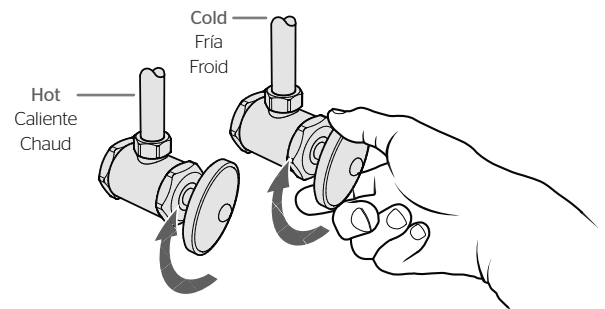

2 Install Faucet Instale el grifo Installer le robinet

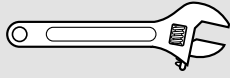

Adjustable Wrench
Llave ajustable
Clé réglable



PTFE plumber's tape
Cinta para plomería PTFE
Ruban PTFE de plombier

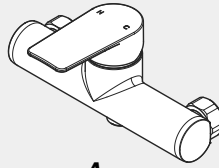

A



B (x2)



C (x2)



D (x2)

OPTION 1: Install Spout *without Adapters (D)* OPCIÓN 1: Instale la boquilla sin adaptadores (D) OPTION 1: Installez Bec sans adaptateurs (D)

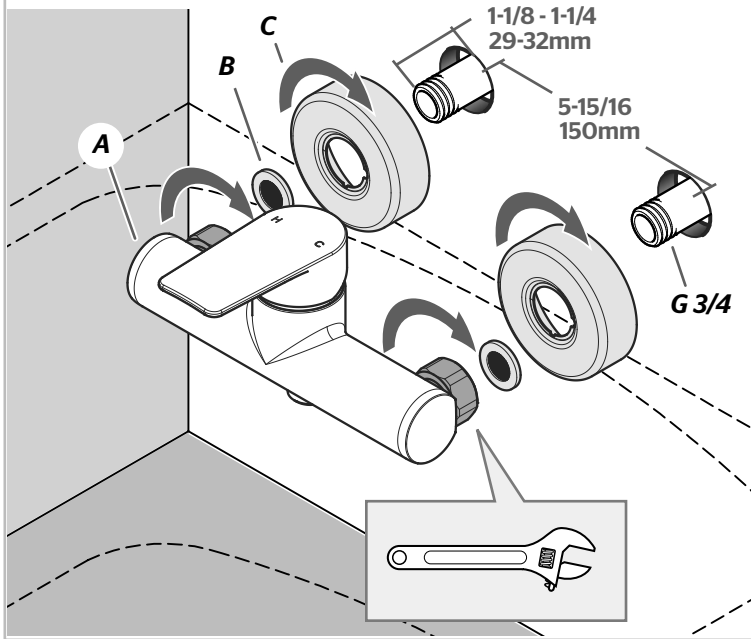

OPTION 2: Install Spout *with Adapters (D)* OPCIÓN 2: Instale con pico Adaptadores (D) OPTION 2: Installez Bec avec des adaptateurs (D)

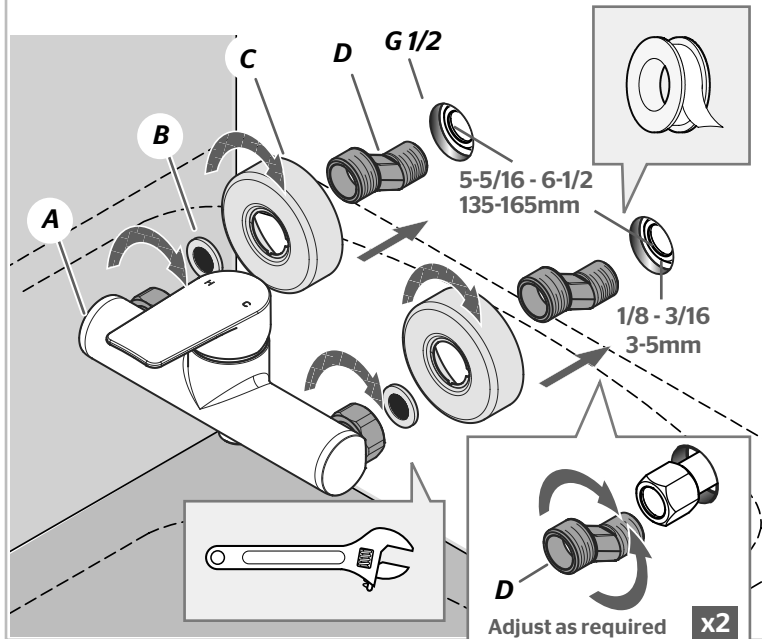

Adjust as required **x2**
Ajuste según sea necesario
Ajustez au besoin

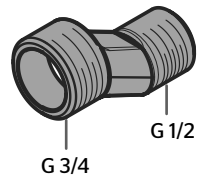

Tip • Indicio • Conseil

Use a towel to protect product during wrench tightening.
Utilice una toalla para proteger el producto durante el apriete de la llave.
Utilisez une serviette pour protéger le produit pendant le serrage de la clé.



Apply PTFE Plumber's Tape or Thread Sealant according to manufacturer's instructions.

Coloque cinta PTFE o Sellador de Roscas de acuerdo con las instrucciones del fabricante.

Appliquez PTFE Plombiers bande ou le scellant de filets selon les instructions du fabricant.

3 Turn On Water & Confirm Proper Installation

Active el suministro de agua y confirme que la instalación está adecuadamente efectuada
Ouvrez l'eau et confirmez que l'installation est correcte

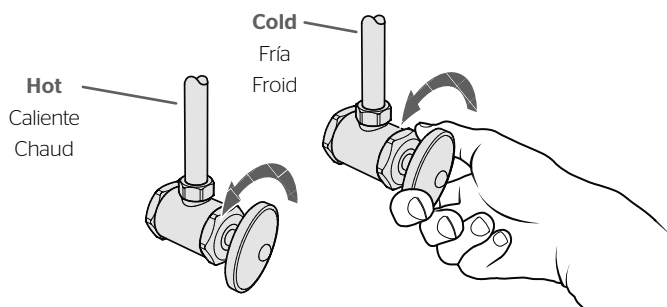

Check all connections for leaks.

Revise todas las conexiones en busca de fugas.
Vérifiez l'étanchéité des raccords.

4

Flush the faucet before using Limpie el grifo con un chorro de agua antes de usar Rincez le robinet avant utilisation

No Tools Required for This Step
No se necesitan herramientas para este paso
Aucun outil n'est nécessaire pour cette étape

No Parts Required for This Step
No se necesitan piezas para este paso
Pas de pièce nécessaire pour cette étape

4A Turn On Faucet Active el grifo Ouvrez le robinet

Open Slowly
Abra lentamente
Ouvrez lentement

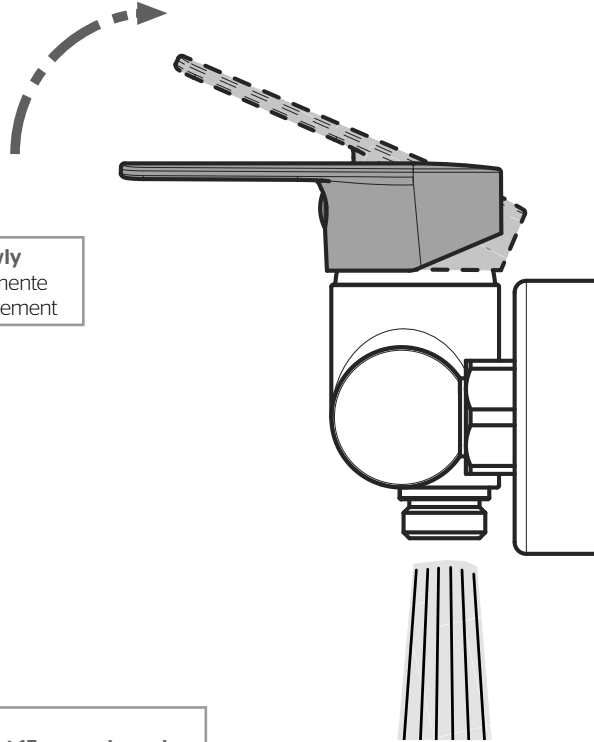

Allow hot & cold water to run for at least 15 seconds each.

Deje correr el agua caliente y fría durante al menos 15 segundos cada una.

Laissez couler l'eau chaude et l'eau froide pendant au moins 15 secondes.

4B

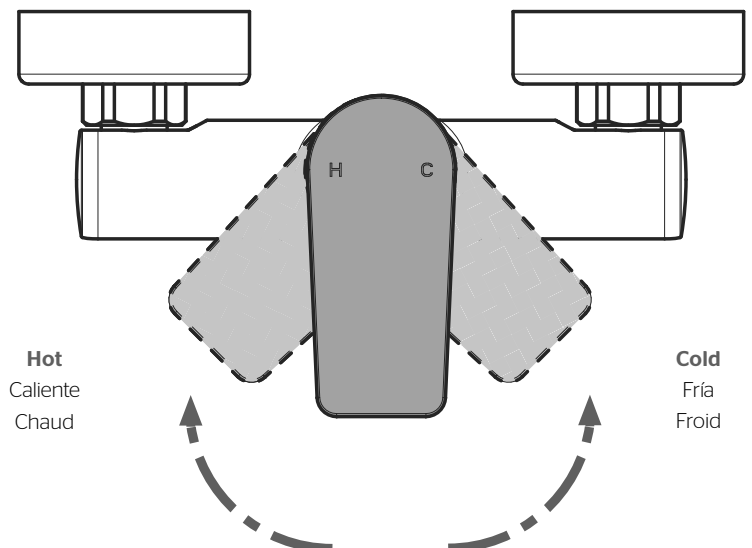

5

Connect Hand Held Shower Hose

Conecta la manguera de ducha de mano

Raccorder le tuyau de la douchette



Adjustable Wrench
Llave ajustable
Clé réglable

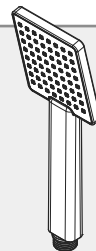

J



K

5B

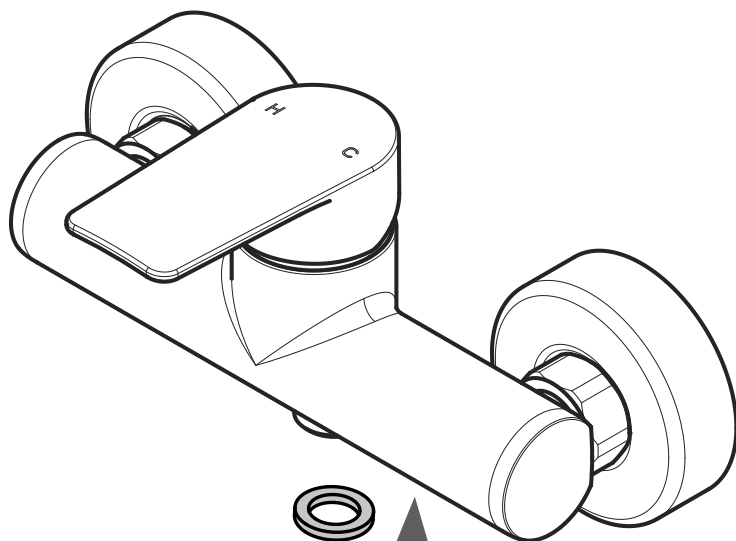

K1

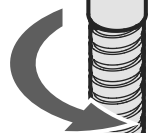
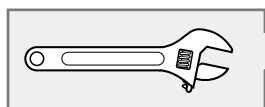

K2

5B

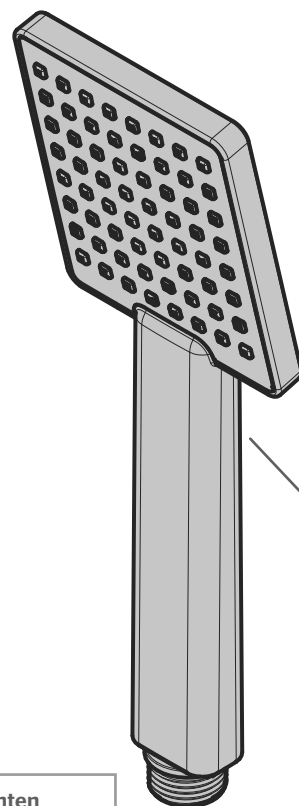

J

Hand Tighten
Apriete con la mano
Serrez manuellement



K3

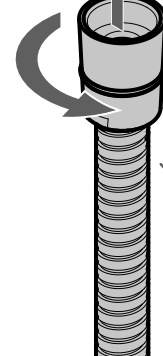

K2

6 Mount Hand Held Shower Holder

Monte titular de la ducha de mano

Support pour douche à main



Hammer
Martillo
Marteau

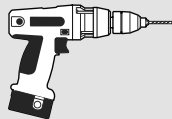

Power Drill
Taladro Eléctrico
Foreuse Électrique

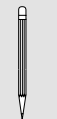

Pencil
Lápiz
Crayon



Phillips Screwdriver
Destornillador de estrella
Tournevis Philips



Safety Goggles
Anteojos de seguridad
Lunettes de sécurité



E



F (x2)



G



H



J

Position Hand Held Shower to preferred location

Posición de la mano se celebraba la ducha en el lugar preferido
Position de la douche à main dans la pratique

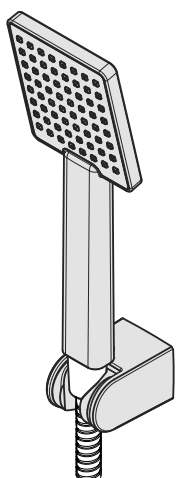

6A

Use to mark desired locations.

Utilice para marcar localizaciones deseada.
Employez pour marquer des endroits désiré.

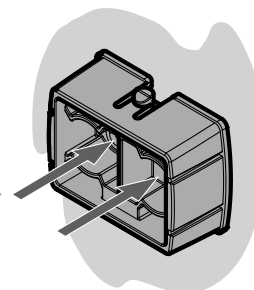
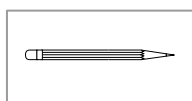

6B

Wall: Drill two 1/4" holes.

Pared: taladre dos orificios de 1/4".

MUR: Percer deux trous de 1/4 po.

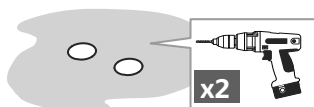

6C

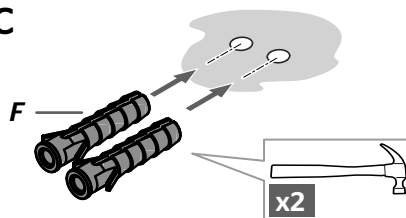

6D

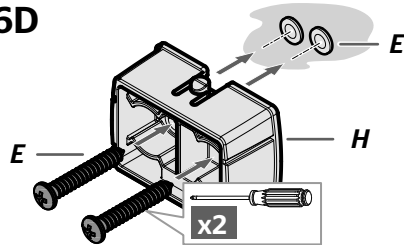

6E

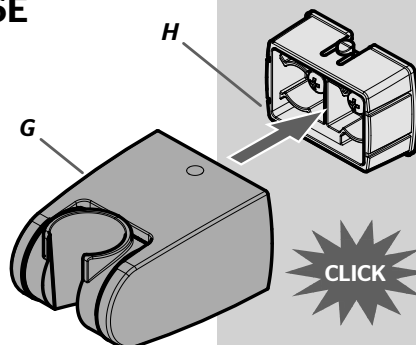

6F

